



## VENDOR FAQs

### WHO SHOULD PARTICIPATE?

We are looking for vendors with unique food, merchandise, and gift options that incorporate our festive holiday theme.

### WHAT ARE THE EVENT DATES AND HOURS?

December 6–23 (closed Dec 9–11) from 4pm to 10pm.

### DO VENDORS NEED TO PARTICIPATE ALL DAYS?

Yes, it is mandatory that all vendors participate all 15 days.

### WHAT ARE THE OPERATIONAL HOURS?

Vendors must be fully operational by 3:45pm and open until 10pm.

On opening day, December 6, vendors must be fully moved-in and set-up by 2pm.

### WHAT HAPPENS IF THERE IS INCLEMENT WEATHER?

The team at the PNE assesses the weather conditions and will inform all vendors if there are any changes to the hours of operation.

### WHEN IS PAYMENT DUE?

Upon acceptance, vendors must pay a booth deposit and sign the contract. Failure to make this payment and sign the contract will result in forfeiture of your booth space. Full booth payment is due November 3, 2024.

### CAN I SHARE BOOTH SPACE WITH ANOTHER VENDOR?

No, vendors are not permitted to share their booth space with other vendors.

### WHAT OTHER INFORMATION IS REQUIRED?

Vendors must provide \$2 Million Public Liability Insurance, WorkSafe BC registration number, and valid clearance letter by November 3, 2024.



## VENDOR FAQs

### **WHEN IS THE APPLICATION DEADLINE?**

November 3, 2024. Applications received after this date are subject to availability.

### **CAN I GET ADDITIONAL ID PASSES?**

Yes, please contact the Exhibit Space team to request additional passes.

### **WHERE WILL I BE PARKING?**

Vendors will be provided with on-site parking.

For more information about the 2024 PNE Winter Fair please visit: [www.pne.ca/winter-fair](http://www.pne.ca/winter-fair)

For additional vendor information and to apply, please visit: [www.pne.ca/winter-fair-vendors](http://www.pne.ca/winter-fair-vendors)

If you have any questions, please email [exhibitsales@pne.ca](mailto:exhibitsales@pne.ca)



# OUTDOOR: POP-UP HOLIDAY MARKET HUT VENDORS

## WHAT ARE THE DIMENSIONS OF THE HUT?

Approximately 9ft by 7ft. See image below for exact dimensions.

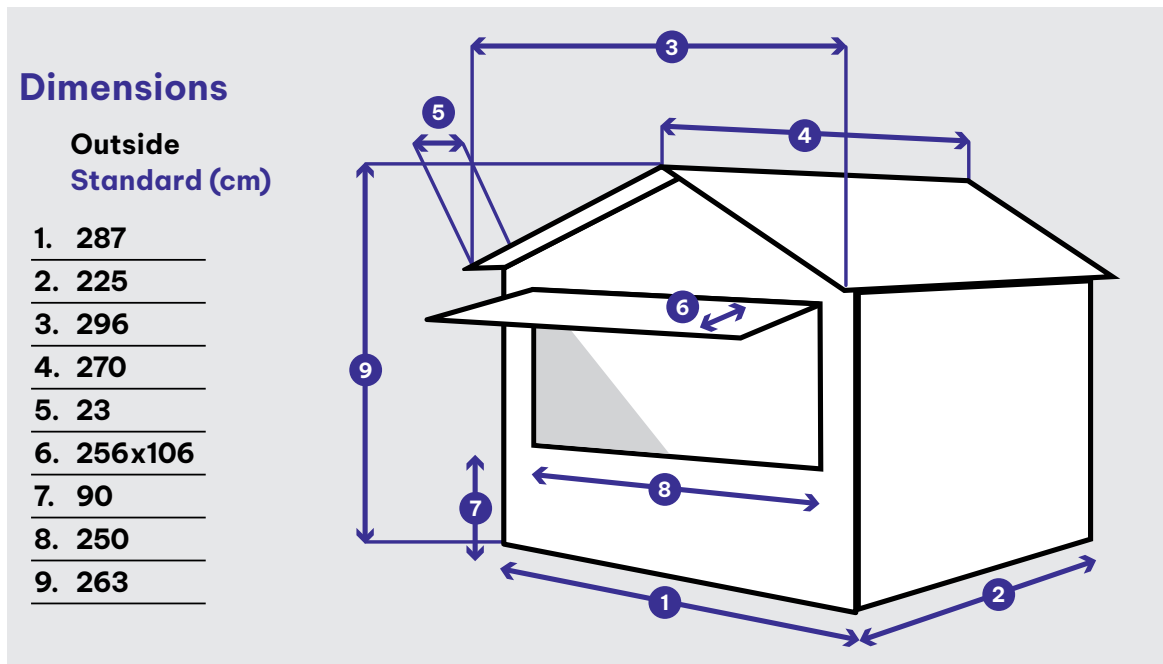

## WHAT IS INCLUDED IN THE COST?

Your hut rental, a 15amp outlet, use of a PNE heater on its own dedicated outlet, 2 ID passes, and 2 on-site parking passes.

## CAN I ORDER ADDITIONAL ELECTRICAL?

Yes, please contact the [Exhibit Space](#) team to order additional electrical.



# OUTDOOR: POP-UP HOLIDAY MARKET HUT VENDORS

## WHEN IS MOVE-IN?

Hut vendor move in begins December 5 and vendors must be moved in by December 6 at 2pm

## WHEN IS MOVE-OUT?

Hut vendor move out begins at 10pm on December 23 and vendors must be fully moved out by midnight.

## HOW CAN I SET UP MY BOOTH?

We allow one rectangular table that must run parallel against the front of the hut (beneath the awning). This table must be covered by a tablecloth and can be up to 96x30 inches.

- Vendors must provide their own lock.
- Drilling and nailing directly onto the Vendor Hut is not permitted.
- Removable utility hooks (ie. Command hooks) must be used if you are fastening anything to the hut.
- Any damages incurred will be subject to a repair fee.



# OUTDOOR: FOOD VENDORS

## **COST:**

25% of Gross Sales plus \$27 C.A.F.E. Fee, and electrical, water/sewer and waste management fees.

**What is included in the cost:** Truck space, electrical, water/sewer, 4 ID passes, and 2 on-site parking passes.

## **WILL I BE USING MY OWN POS TERMINAL?**

No, you will receive a PNE-issued terminal to process payments. No cash sales are permitted. Vendors are required to pay an additional 1% processing fees. Vendors must pay a refundable \$425 POS terminal deposit. Payout dates are TBD.

## **CAN I MOVE MY TRUCK OFF-SITE ON DAYS THAT ARE CLOSED?**

No. As vendors must be plumbed in and connected to our electrical utilities, vendors are required to keep their food truck on site from initial move-in until the end of the Winter Fair. Move-out begins after 10pm on December 23.

## **WHEN DO I NEED TO MOVE-IN?**

Food Vendor move-in begins Monday, December 2. Vendors must be moved in by Wednesday, December 4. Vendors must be on-site for VCH inspections on December 5.

## **WHEN DO I NEED TO MOVE-OUT?**

Food Vendors can move out after 10pm on December 23. The grounds will be closed from December 24-27. Vendors can resume moving out on December 28 and must be fully vacated by 4pm.

## **CAN I USE A TENT AS MY BOOTH SET-UP?**

No, we do not allow the use of tents for outdoor food vendors.